



Electrolux
PROFESSIONAL

**Modular Cooking Range Line
thermaline 90 - 4 Zone Full Surface
Induction Top on Open Base, 1 Side,
H=700**

ITEM # _____

MODEL # _____

NAME # _____

SIS # _____

AIA # _____



589728 (MCJDEAJIAA)

Free-zone Induction on open base (34x74x33h cm), H2, 4 zones, 1-side operated

Short Form Specification

Item No. _____

Unit constructed according to DIN 18860_2 with 20 mm drop nose top and 70 mm recessed plinth. Internal frame for heavy duty sturdiness in stainless steel. 2 mm top in 1.4301 (AISI 304). Flat surface construction, easily cleanable. THERMODUL connection system enables seamless worktop when units are connected and avoids soil penetrating. Free zone multi-coil glass ceramic surface without dead spots can host up to 16 pots&pans. Minimum cookware diameter is 7 mm. UI design to control each coil independetly, power (W) and temperature settings are possible. Overheat protection switches off the supply in case of overheating. IPX5 water resistance certification. Configuration: Freestanding, one-side operated, on open base, hygienic class H2.

Main Features

- The free zone induction offers the possibility to use multiple pots and pans, even small sizes (min diameter 7 cm), thanks to the multi-coil system design that makes all the surface active, ideal for à la carte menu.
- The smooth glass-ceramic surface features limited temperature increase and it can be quickly and easily cleaned, thus providing maximum hygiene.
- THERMODUL connection system creates a seamless work top when units are connected to each other thus avoiding soil penetrating vital components and facilitating the removal of units in case of replacement or service.
- 360° round stepless metal knobs, working clock and anticlock wise for quick parameters selection and adjustment.
- Each zone is controlled by a touch-sensitive keypad with 7 touch buttons, 4 displays and a round knob. Each zone consists in 4 coils, which can be individually controlled or bridged in 2, 3 or 4. Power (watts) or temperature (°C) can be selected. A function is also available to set and save 3 different configurations.
- Power setting from 25 to 2000 watt in 30 steps or temperature settings from 30 to 250° C in steps of 1°C.
- Electronic sensor, placed underneath the glass, below the coil center position, to precisely measure the temperature of the pan/pot bottom
- Overheat protection: the temperature sensor switches off the supply in case of overheating.
- Heating system automatically switches off when pots and pans are removed.
- Low heat dissipation to the kitchen.

Construction

- Unit constructed according to DIN 18860_2 with 20 mm drop nose top and 70 mm recessed plinth.
- Flat surface construction with minimal hidden areas to easily clean all surfaces
- Internal frame for heavy duty sturdiness in stainless steel.
- All major components may be easily accessed from the front, including the induction filters.
- 2 mm top in 1.4301 (AISI 304).
- 34x74x33 cm (wxdxh) open base with round corners H2 for storage.
- IPX5 water resistance certification.

Sustainability

- This model is compliant with Swiss Energy Efficiency Ordinance (730.02).



APPROVAL: _____



Experience the Excellence
www.electroluxprofessional.com

Optional Accessories

- Scraper for cook tops PNC 910601
- Connecting rail kit, 900mm PNC 912502
- Stainless steel side panel, 900x700mm, freestanding PNC 912512
- Portioning shelf, 1000mm width PNC 912528
- Portioning shelf, 1000mm width PNC 912558
- Folding shelf, 300x900mm PNC 912581
- Folding shelf, 400x900mm PNC 912582
- Fixed side shelf, 200x900mm PNC 912589
- Fixed side shelf, 300x900mm PNC 912590
- Fixed side shelf, 400x900mm PNC 912591
- Stainless steel front kicking strip, 1000mm width PNC 912636
- Stainless steel side kicking strip left and right, freestanding, 900mm width PNC 912657
- Stainless steel side kicking strip left and right, back-to-back, 1810mm width PNC 912663
- Stainless steel plinth, freestanding, 1000mm width PNC 912960
- Connecting rail kit: modular 90 (on the left) to ProThermetic tilting (on the right), ProThermetic stationary (on the left) to ProThermetic tilting (on the right) PNC 912975
- Connecting rail kit: modular 80 (on the right) to ProThermetic tilting (on the left), ProThermetic stationary (on the right) to ProThermetic tilting (on the left) PNC 912976
- Endrail kit, flush-fitting, left PNC 913111
- Endrail kit, flush-fitting, right PNC 913112
- Endrail kit (12.5mm) for thermaline 90 units, left PNC 913202
- Endrail kit (12.5mm) for thermaline 90 units, right PNC 913203
- Stainless steel side panel, left, H=700 PNC 913222
- Stainless steel side panel, right, H=700 PNC 913223
- T-connection rail for back-to-back installations without backsplash (to be ordered as S-code) PNC 913227
- Insert profile d=900 PNC 913232
- Perforated shelf for warming cabinets and cupboard bases (one-side operated TL80-85-90 and two-side operated for TL80) PNC 913233
- Endrail kit, (12.5mm), for back-to-back installation, left PNC 913251
- Endrail kit, (12.5mm), for back-to-back installation, right PNC 913252
- Endrail kit, flush-fitting, for back-to-back installation, left PNC 913255
- Endrail kit, flush-fitting, for back-to-back installation, right PNC 913256
- Side reinforced panel only in combination with side shelf, for freestanding units PNC 913260
- Side reinforced panel only in combination with side shelf, for back-to-back installations, left PNC 913275
- Side reinforced panel only in combination with side shelf, for back-to-back installation, right PNC 913276
- Shelf fixation for TL80-85-90 one-side operated, TL80 two-side operated PNC 913279

- Filter W=1000mm PNC 913666
- Stainless steel dividing panel, 900x700mm, (it should only be used between Electrolux Professional thermaline Modular 90 and thermaline C90) PNC 913672

- Stainless steel side panel, 900x700mm, flush-fitting (it should only be used against the wall, against a niche and in between Electrolux Professional thermaline and ProThermetic appliances and external appliances - provided that these have at least the same dimensions) PNC 913688
- Peak management system for Free-zone Induction, half module (8 coils) PNC 921026

Recommended Detergents

- C41 HI-TEMP RAPID DEGREASER, 1 pack of six 1 lt. bottles (trigger incl.) PNC 0S2292
- S01 STAINLESS STEEL SURFACE POLISHER; 6 BOTTLES X 750ML C/T PNC 0S2881
- S02 Degreaser for ovens and SpeedDelight. Specific for cleaning the cooking chambers of GourmeXpress and SpeeDelight. Active up to a maximum of 50°C. Complete with spray bottle Pack of 6 750ml bottles PNC 0S2882
- S03 ALCOHOL BASE DETERGENT; 6 BOTTLES X 750ML; ADR&IMDG&IATA Limited Quantity PNC 0S2883
- S04 GLASSES & HARD SURFACES CLEANERS; 6 BOTTLES X 750ML PNC 0S2884
- S05 - MULTIPURPOSE DEGREASER; 6PCS X 750ML; ADR&IMDG Limited Quantity PNC 0S3257

Front

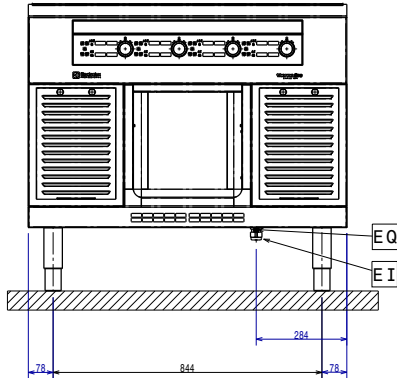

Side

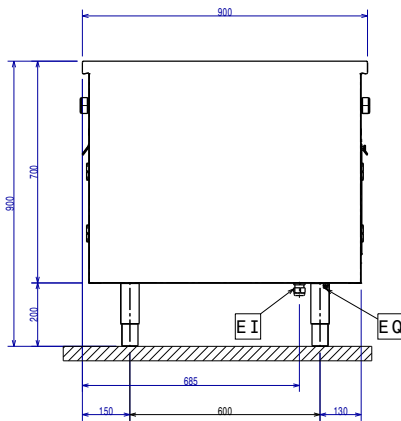

EI = Electrical inlet (power)
 EQ = Equipotential screw

Top

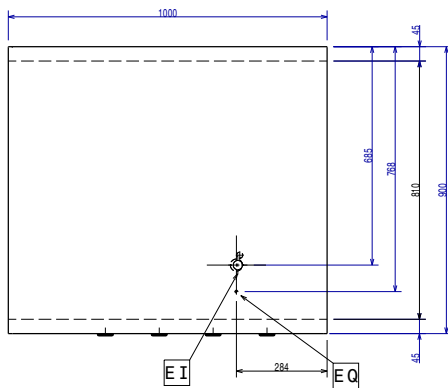

Electric

Supply voltage: 400 V/3N ph/50/60 Hz
 Total Watts: 32 kW

Key Information:

External dimensions, Width: 1000 mm
 External dimensions, Depth: 900 mm
 External dimensions, Height: 700 mm
 Storage Cavity Dimensions (width): 340 mm
 Storage Cavity Dimensions (height): 330 mm
 Storage Cavity Dimensions (depth): 738.5 mm
 Net weight: 120 kg
 Configuration: On Base; One-Side Operated
 Front Plates Power: 8 - 8 kW
 Back Plates Power: 8 - 8 kW
 Front Plates dimensions: 320x320 320x320
 Back Plates dimensions: 320x320 320x320
 Induction Top Dimensions (width): 1000 mm
 Induction Top Dimensions (depth): 900 mm

Sustainability

Current consumption: 43 Amps